



Models PT-91, PT-92, PT-93, PT-94, PT-95

SPECIFICATIONS

Models PT-91, PT-92, PT-93, PT-94 and PT-95 are five (5) tube A.C. or D.C. operated Superheterodyne compact radios employing a built-in loop aerial. These models are similar with the exception of the cabinets and loops. Model PT-91 is assembled in a walnut plastic cabinet, Model PT-92 in a white plastic cabinet, Model PT-93 in a dark wood cabinet, PT-94, walnut cabinet, and PT-95, walnut cabinet, ivory trim.

In addition each Model includes a tuning band from 535 to 1620 K.C., Automatic Volume Control; Beam power pentode audio output stage and Philco Loktal tubes.

INTERMEDIATE FREQUENCY: 455 K.C.

AUDIO OUTPUT: 1 Watt.

CABINET DIMENSIONS:	Height	Width	Depth
Models PT-91, PT-92	6 1/8"	10 1/8"	5 1/8"
Model PT-93	8 1/8"	11 3/4"	6 1/8"
Models PT-94, PT-95	7"	13"	6"

POWER SUPPLY: 115 Volts, A.C. or D.C.

PHILCO TUBES: 7A8, converter; 7B7, I. F. Amplifier; 7C6, 2nd detector, A. V. C., 1st audio; 50L6GT, beam power audio output and a 35Z3, rectifier.

AERIAL AND GROUND: Under ordinary operating conditions an outside aerial or ground is not required. In some locations, however, such as steel reinforced buildings and other shielded areas, an outside aerial should be used for maximum performance. For this purpose an outside aerial connection is located on the rear lower left corner of the chassis. Simply remove the lug from under the screw and attach the aerial lead to the lug. **PHILCO AERIAL**, Part No. 40-6370, is especially designed for these radios, and can be obtained from your Philco Distributor.

ALIGNING R. F. AND I. F. COMPENSATORS EQUIPMENT REQUIRED

- SIGNAL GENERATOR:** Covering the frequency range of the receiver, such as Philco Models 070 or 177.
- ALIGNING INDICATOR:** Either a vacuum tube voltmeter or an audio output meter may be used as an aligning indicator. Philco Models 027 or 028 circuit testers contain both these meters.
- TOOLS:** Philco Fiber Screw Driver, Part No. 45-2610.

CONNECTING ALIGNING INSTRUMENTS

Audio Output Meter: If this type of aligning meter is used, connect it to the voice coil terminals of the speaker on the outside aerial terminal panel, or from the plate of the 50L6GT tube to B (—) negative. Adjust the meter for the 0 to 10 volt scale.

Vacuum Tube Voltmeter: To use the vacuum tube voltmeter as an aligning indicator, make the following connections: Attach the negative (—) terminal of the voltmeter to any point in the circuit where the A. V. C. voltage can be obtained. Connect the positive (+) terminal of the vacuum tube volt meter to the chassis.

Signal Generator: When adjusting the I.F. padders, the high side of the signal generator is connected through a .1 mfd. condenser to the antenna sec-

tion of the tuning condenser. Connect the ground or low side of the generator to the chassis.

When aligning the R. F. padders a loop is made from a few turns of wire and connected to the signal generator output terminals; the signal generator is then placed close to the loop of the radio.

The receiver can be adjusted in the cabinet or removed from the cabinet.

When adjusting the radio outside the cabinet the loop aerial should be placed in approximately the same position near the chassis as when assembled.

After connecting the aligning instruments adjust the compensators as shown in the tabulation below. Locations are shown on Schematic.

If the indicating meter pointer goes off scale when adjusting the compensators, reduce the strength of the signal from the generator.

Operations in Order	SIGNAL GENERATOR		RECEIVER			SPECIAL INSTRUCTIONS
	Output Connections to Receiver	Dial Setting	Dial Setting	Control Setting	Adjust Compensators in Order	
1.	Ant. Section of tuning	455 K.C.	540 K.C. Tuning Cond. Closed	Vol. Max.	12A, 12B, 10A, 10B	Note B
2.	Loop see above instructions	1500 K.C.	1500 K.C.	Vol. Max.	4B	Note A
3.	Loop see above instructions	1500 K.C.	1500 K.C.	Vol. Max.	4A	

NOTE A: DIAL POINTER CALIBRATION — In order to adjust the receiver correctly, the pointer must be adjusted to track properly with the tuning condenser. To do this, turn the tuning condenser to the maximum capacity (plates fully meshed). With the condenser in this position, set the tuning pointer on the small dot below 550 K.C.

Note B — Before adjusting compensators, turn down (10B) to tight position. Then adjust the compensators for maximum output in the following order: 12A, 12B, 10A and 10B.

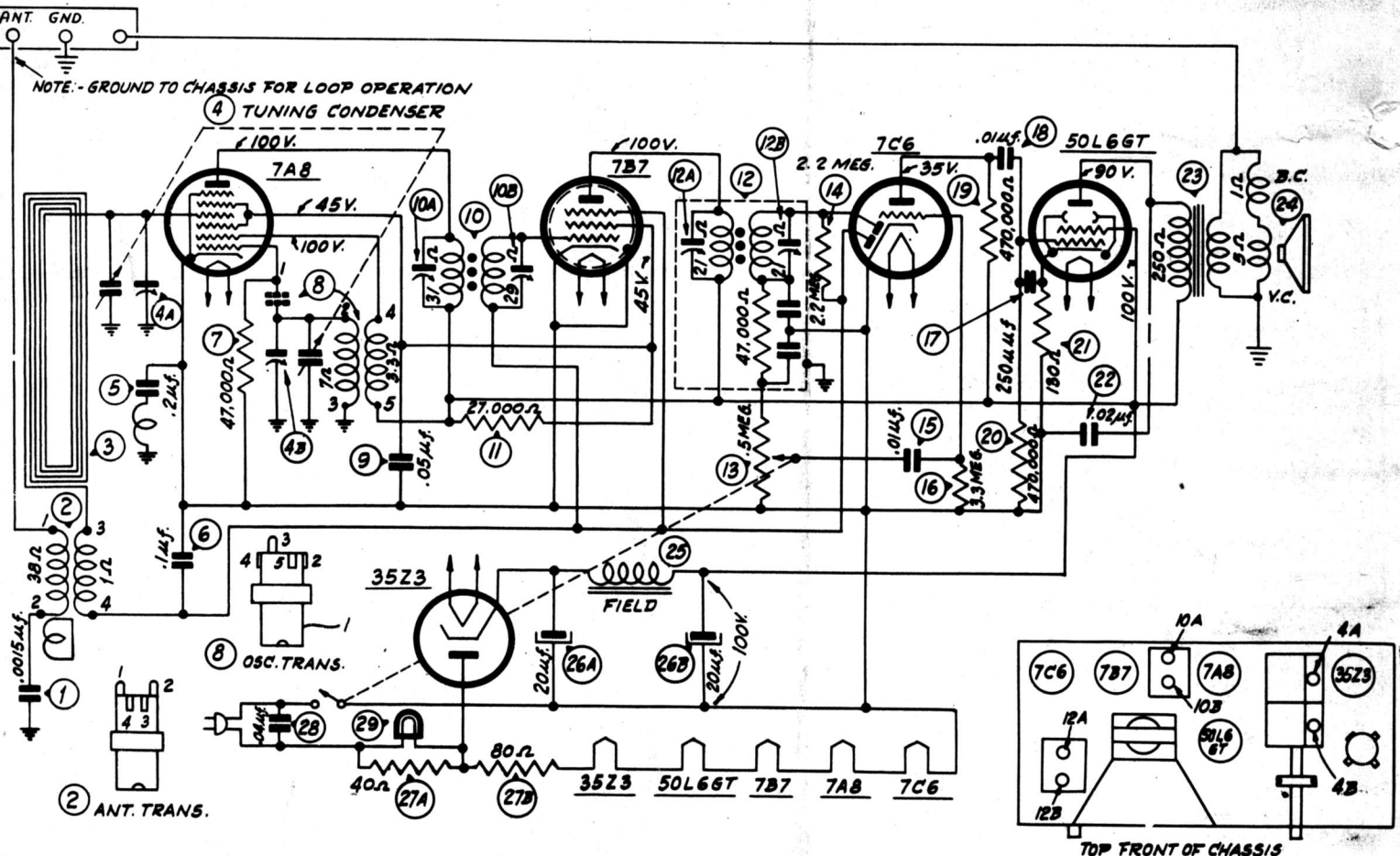

SCHEMATIC DIAGRAM — MODELS PT-91, PT-92, PT-93, PT-94, PT-95

The tube socket voltages indicated on the diagram were measured with a 1,000 ohms per voltmeter — PHILCO Model 027, line voltage 117 volts A.C.

REPLACEMENT PARTS

SCHEM. No.	DESCRIPTION	PART No.
1.	Condenser (.0015 mfd., 200 volts)	30-4621
2.	Aerial Transformer	32-3394
	Mtg. Clip	28-5002
3.	Loop Aerial (PT-91 part of Cabinet)	
	Loop Aerial (PT-92 part of Cabinet)	
	Loop Aerial (PT-93)	32-3835
	Loop Aerial (PT-94, PT-95)	32-3855
4.	Tuning Cond.	31-2539
	Dial Pointer	54-4043
	Mtg. Grommet	27-4610
	Spring (Drive cord)	28-8954
	Tuning Shaft	31-2518
	Mtg. Nut	W-2157
	Drive Cord	31-2541
5.	Condenser & Choke Assembly	76-1161
6.	Condenser (.1 mfd., 200 volts)	30-4586
7.	Resistor (47,000 ohms)	33-347339
8.	Oscillator Transformer	32-3686
	Mtg. Clip	28-5002
9.	Condenser (.05 mfd., 200 volts)	30-4519
10.	1st I. F. Transformer	32-3673
	Mtg. Nut	W-624
11.	Resistor (27,000 ohms)	33-327339
12.	2nd I. F. Transformer	32-3674
	Mtg. Nut	W-624
13.	Volume Control	33-5429
	Nut	W-1949
14.	Resistor (2.2 megohms)	33-522339
15.	Cond. (.01 mfd., 400 volts)	30-4572
16.	Resistor (3.3 megohms)	33-533339
17.	Mica Cond. (250 mmfd.)	60-125157
18.	Cond. (.01 mfd., 400 volts)	30-4572
19.	Resistor (470,000 ohms)	33-447339
20.	Resistor (470,000 ohms)	33-447339
21.	Resistor (130 ohms)	33-113336
22.	Condenser (.02 mfd., 400 volts)	30-4516
23.	Output Transformer	32-8164
24.	Cone Assembly (for Speaker 36-1542-9)	36-4204
25.	Field Coil (Replace Speaker 36-1542)	
26A.	Electrolytic Condenser (20-20 mfd.)	30-2382

SCHEM. No.	DESCRIPTION	PART No.
26B.	Electrolytic Condenser (20 mfd.) part of 26A	
27.	Clamp	56-1346
28.	Resistor (40-80 ohms)	33-3408
29.	Cond. (.04 mfd., 400 volts)	30-4119
	Pilot Lamp	34-2068
	Socket Assembly	76-1280
MISCELLANEOUS PARTS		
	Cabinet PT-91	76-1249
	Cardboard back PT-91	27-9879
	Mtg. Fastener	45-6196
	Cabinet PT-92	76-1321
	Cardboard back PT-92	27-9922
	Mtg. Fastener	45-6196
	Cabinet PT-93	10585A
	Cardboard back PT-93	27-9952
	Cabinet (PT-94)	10553A
	Cabinet back	29-9972
	Bezel	54-4117
	Baffle & Cloth	40-6691
	Cabinet (PT-95)	10553A
	Cabinet back	27-9973

SCHEM. No.	DESCRIPTION	PART No.
	Bezel	54-4152
	Baffle & Cloth	40-6693
	Cable (Power)	L-3199
	Dial Scale (PT-91, PT-92)	27-5713
	Mtg. Screw (Dial) PT-91	W-523
	Dial Scale (PT-93)	27-5797
	Mtg. Screw (PT-93)	W-758
	Dial Scale (PT-94, PT-95)	27-5802
	Dial (Window) PT-91, PT-92	54-4088
	Dial (Window) PT-94, PT-95	27-5616
	Fastener (Dial Window)	56-1387
	Screw	W-523
	Washer	W-152
	Knob Assembly (PT-91)	27-4820
	Knob (PT-92)	54-4118
	Knob (PT-93)	54-4137
	Knob (PT-94)	27-4809
	Knob (PT-95)	27-4810
	Sockets (tubes)	27-6177
	Sockets (50L6GT)	27-6174
	Speaker	36-1542
	Washer (Chassis)	W-410
	Screw (Chassis)	W-1921

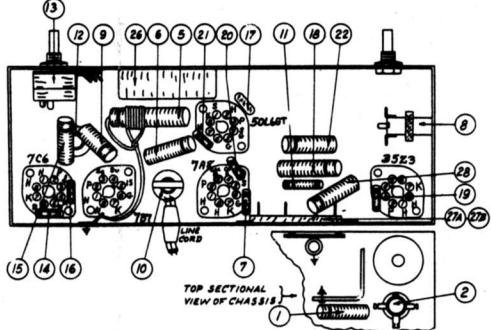

FIG. 1 — LOCATIONS OF PARTS — UNDERSIDE OF CHASSIS.